

# ELEVACION TECHOS (SIMPLE)

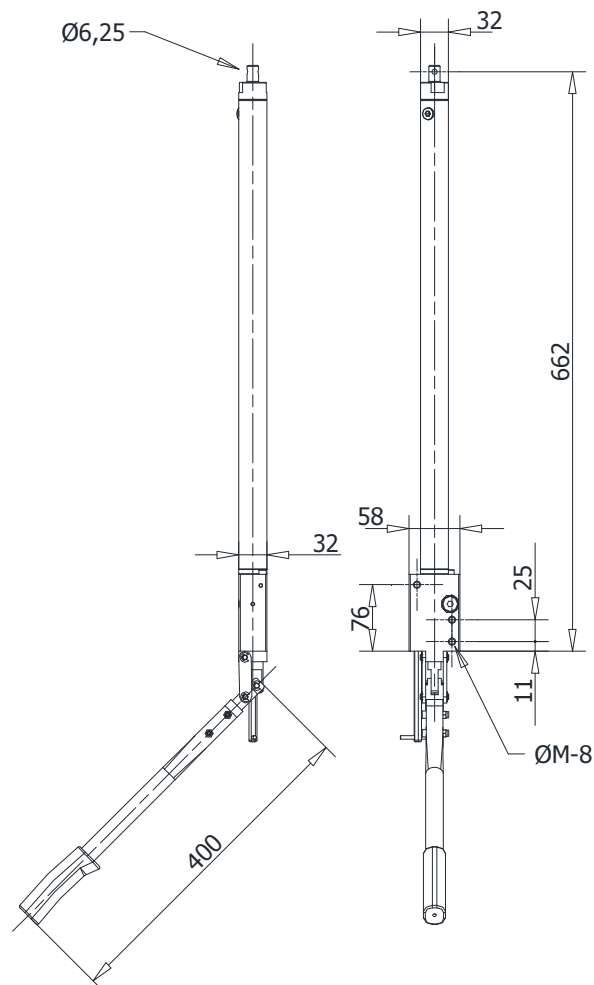

*El techo debe poder admitir esta deformación*

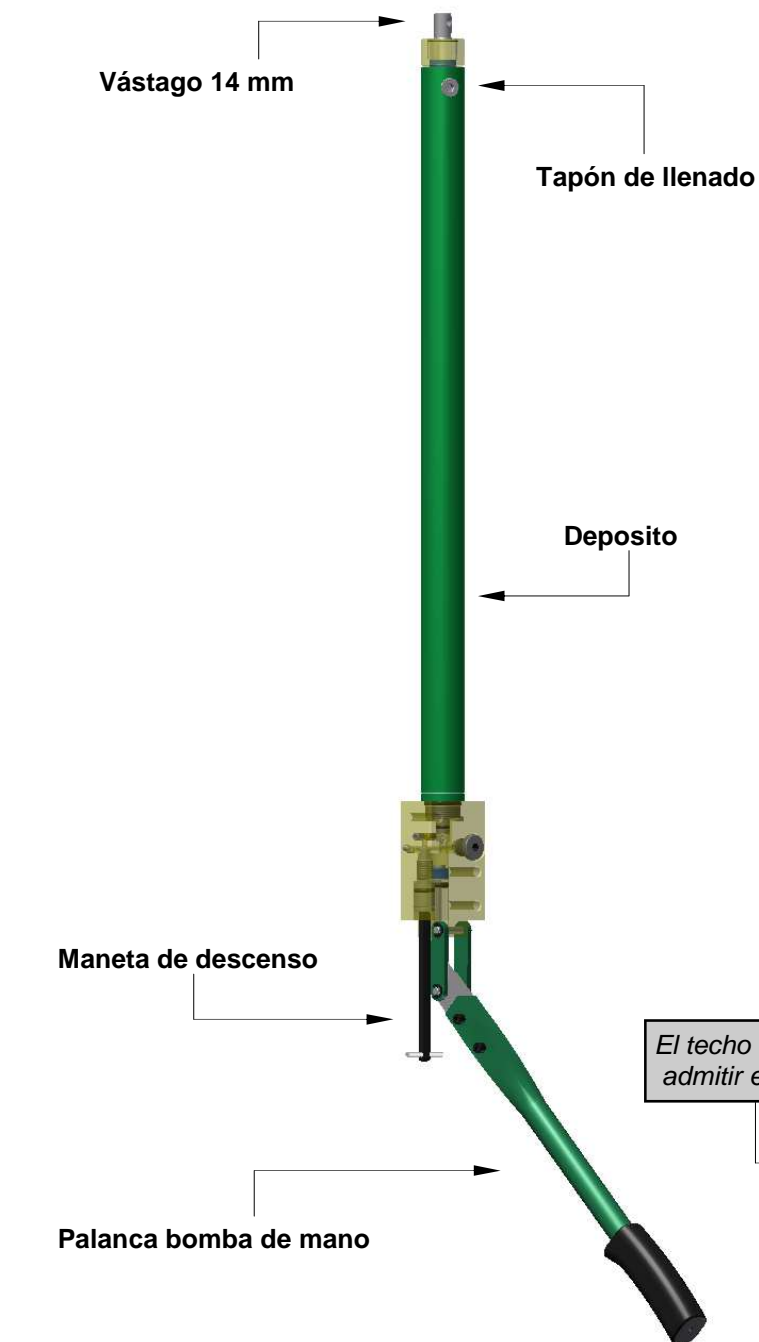
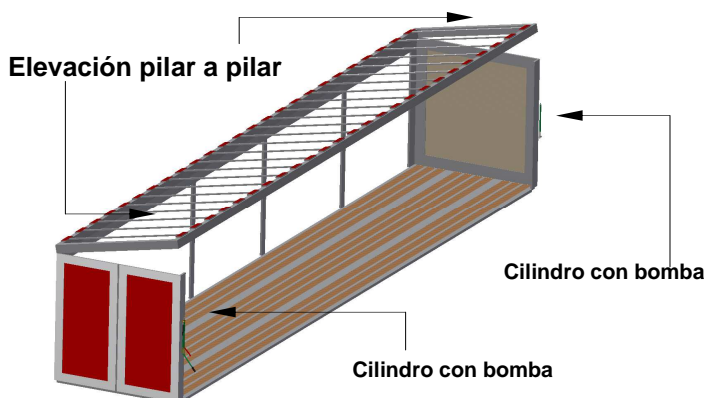
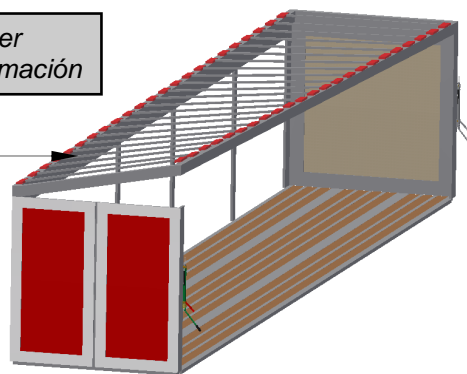

CARACTERÍSTICAS	
Presión Max. (bar)	250
Capacidad deposito (Cm3)	190
Carrera (mm)	450
Volumen por embolada (Cm3)	5,2
Diámetro vástago (mm)	14
Peso Max a elevar (Kg)	350
Peso cilindro autónomo (Kg)	4,1
Temperatura (°C)	-30... +50